

---

**TEK**INSTRUCTION  
MANUALPart No. 070-6949-00  
Product Group 60

---

# P6204

## FET PROBE

### 10 M OHM, 10X, ID

*Please Check for  
CHANGE INFORMATION  
at the Rear of This Manual*

---

Revised NOV 1990

**Tektronix**<sup>®</sup>  
COMMITTED TO EXCELLENCE

Copyright © 1988/1989 Tektronix, Inc. All rights reserved. Contents of this publication may not be reproduced in any form without the written permission of Tektronix, Inc.

Products of Tektronix, Inc. and its subsidiaries are covered by the listed specific U.S. and foreign patents, and may be covered by related and/or pending patents.

US Patent # 4708661

TEKTRONIX, and TEK are registered trademarks of Tektronix, Inc. TELEQUIPMENT is a registered trademark of Tektronix U.K. Limited.

Printed in U.S.A. Specification and price change privileges are reserved.

# TABLE OF CONTENTS

	Page
LIST OF ILLUSTRATIONS .....	v
LIST OF TABLES .....	vii
OPERATORS SAFETY SUMMARY .....	viii
SERVICING SAFETY SUMMARY .....	ix
<b>SECTION 1 SPECIFICATION</b>	
DESCRIPTION .....	1-1
ACCESSORIES .....	1-1
PERFORMANCE CONDITIONS .....	1-1
<b>SECTION 2 - OPERATING INSTRUCTIONS</b>	
INTRODUCTION .....	2-1
OPERATING CONSIDERATIONS .....	2-1
Probe Handling .....	2-1
Input Linear Dynamic Range .....	2-1
High Amplitude Frequency Response .....	2-1
Probe Grounding .....	2-2
CONTROLS AND CONNECTORS .....	2-6
PROBE ACCESSORIES .....	2-6

# TABLE OF CONTENTS (cont.)

## SECTION 3 - PERFORMANCE CHECK

	Page
PURPOSE . . . . .	3-1
TEST EQUIPMENT REQUIRED . . . . .	3-1
LIMITS AND TOLERANCES . . . . .	3-1
PREPARATION . . . . .	3-1
PROCEDURE STEPS . . . . .	3-3
Output Zero Check . . . . .	3-3
DC Offset Range Check . . . . .	3-3
Attenuation Accuracy . . . . .	3-4
Bandwidth, Risetime and HF Aberrations Check . . . . .	3-5

## SECTION 4 - ADJUSTMENT PROCEDURE

PURPOSE . . . . .	4-1
TEST EQUIPMENT REQUIRED . . . . .	4-1
ADJUSTMENT SEQUENCE . . . . .	4-1
ADJUSTMENT LOCATIONS . . . . .	4-1
PREPARATION . . . . .	4-1
PROCEDURE STEPS . . . . .	4-2
Adjust Output Zero . . . . .	4-2
Adjust Offset Range . . . . .	4-2
Adjust Output Zero . . . . .	4-3
Adjust Attenuation Accuracy . . . . .	4-3

# TABLE OF CONTENTS (cont.)

## SECTION 5 - THEORY OF OPERATION

	Page
INTRODUCTION . . . . .	5-1
CIRCUIT DESCRIPTION . . . . .	5-1
COMPENSATION BOX . . . . .	5-1

## SECTION 6 - MAINTENANCE

INTRODUCTION . . . . .	6-1
STATIC-SENSITIVE COMPONENTS . . . . .	6-1
PREVENTIVE MAINTENANCE . . . . .	6-3
CLEANING . . . . .	6-3
VISUAL INSPECTION . . . . .	6-4
SEMICONDUCTOR CHECKS . . . . .	6-4
TROUBLESHOOTING . . . . .	6-5
TROUBLESHOOTING TECHNIQUES . . . . .	6-9
CORRECTIVE MAINTENANCE . . . . .	6-10
MAINTENANCE PRECAUTIONS . . . . .	6-10
OBTAINING REPLACEMENT PARTS . . . . .	6-10
ASSEMBLY REPLACEMENT . . . . .	6-11
READJUSTMENT AFTER REPAIR . . . . .	6-15
INSTRUMENT REPACKING . . . . .	6-16

# TABLE OF CONTENTS (cont.)

## SECTION 7 - DIAGRAMS

	Page
ELECTRICAL DIAGRAMS	
Main Board . . . . .	7-3
Flex Board . . . . .	7-4
Probe Head Hybrid . . . . .	7-5
Main Circuit Board Component Layout . . . . .	7-6

## SECTION 8 - REPLACEABLE PARTS

REPLACEABLE PARTS INFORMATION . . . . .	8-1
REPLACEABLE PARTS DIAGRAM . . . . .	8-2
REPLACEABLE PARTS LIST . . . . .	8-3
OPTIONAL ACCESSORIES LIST . . . . .	8-4

# LIST OF ILLUSTRATIONS

Figure		Page
	The P6204 Probe . . . . .	x
1-1	Typical input impedance versus frequency . . . . .	1-6
1-2	Operating voltage derating . . . . .	1-6
1-3	Typical linearity curve . . . . .	1-7
2-1	Typical linear operating region for step inputs . . . . .	2-2
2-2	Typical -3dB frequency vs amplitude . . . . .	2-3
2-3	Damaging effects of ground-lead inductance . . . . .	2-4
2-4	Inductance reducing connectors . . . . .	2-5
2-5	Controls, connectors and probe accessories . . . . .	2-7
4-1	Compensation box adjustment locations . . . . .	4-2
5-1	Functional block diagram . . . . .	5-2
6-1	Compensation box disassembly . . . . .	6-11
6-2	Assembly replacement . . . . .	6-13
6-3	Flex circuit board replacement . . . . .	6-14
7-1	Main circuit board schematic . . . . .	7-3
7-2	Flex circuit board schematic . . . . .	7-4
7-3	Probe head circuit board schematic . . . . .	7-5
7-4	Main circuit board component layout . . . . .	7-6





# LIST OF TABLES

<b>Table</b>		<b>Page</b>
1-1	Electrical Characteristics . . . . .	1-2
1-2	Environmental Characteristics . . . . .	1-5
1-3	Physical Characteristics . . . . .	1-5
3-1	Test Equipment Required . . . . .	3-2
6-1	Relative Susceptibility to Static Discharge Damage . . . . .	6-1
6-2	Troubleshooting Equipment . . . . .	6-5
6-3	Fault Indication and Probable Cause . . . . .	6-6

# OPERATORS SAFETY SUMMARY

The general safety information in this part of the summary is for both operating and servicing personnel. Specific warnings and cautions will be found throughout the manual where they apply, but may not appear in this summary.

## Terms In This Manual

### **WARNING**

**WARNING** statements identify conditions or practices that could result in personal injury or loss of life.

### **CAUTION**

**CAUTION** statements identify conditions or practices that could result in damage to the equipment or other property.

## **Do Not Operate In Explosive Atmospheres**

To avoid explosion, do not operate this product in any explosive atmosphere unless it has been specifically certified for such operation.

## **Do Not Remove Covers**

To avoid personal injury, do not remove the product covers. Do not operate the product without the covers properly installed.

# SERVICE SAFETY SUMMARY

## *FOR QUALIFIED SERVICE PERSONNEL ONLY*

## **Do Not Service Alone**

Do not perform internal service or adjustment of this product unless another person capable of rendering first aid and resuscitation is present.

## **Use Care When Servicing With Power On**

To avoid personal injury, do not touch exposed connections and components while power is on.

# CAUTION — Important Handling Precautions



*The P6204 FET Probe is designed to provide long-term, trouble-free performance. However, because of the P6204's hybrid-circuit technology and the miniature package design, delicate components and materials are used to construct this active probe. Therefore, the following rules must be followed to avoid probe damage:*

**Do not apply excessive side leverage to probe head**

For example, when the probe is connected to a probe-tip adapter, pulling on the probe cable from the side will damage the internal circuitry.

**Do not drop probe onto a hard surface**

For example, dropping the probe from a bench top onto a hard-surface floor will damage the internal circuitry.

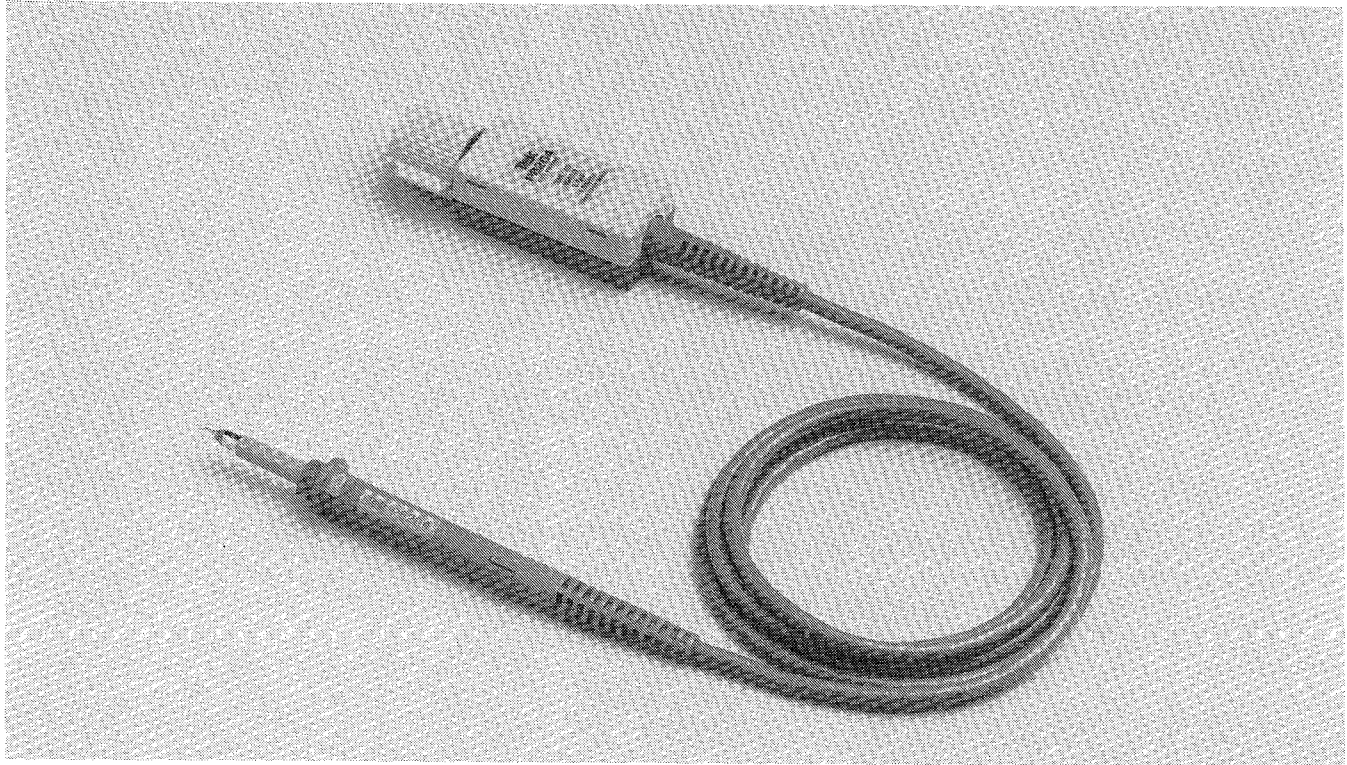

The P6204 Probe.

# SPECIFICATION

## DESCRIPTION

The TEKTRONIX P6204 is a high-impedance, miniature, 10X active (FET) probe with *identify* function. The probe is designed to provide maximum performance with the 11000 Series oscilloscopes and is equipped with the TEKPROBE™ interface which provides data communication between the probe and oscilloscopes and conveys power from the host instrument. Data contained within the probe informs the instrument of the probe's attenuation, model number, and serial number, and causes the input to automatically terminate with 50  $\Omega$ . The ID button on the probe head activates the *identify* function in the instrument. The ID signal can also set an SRQ (Service Request) flag on an IEEE-488 bus if the instrument is programmed to do so.

The P6204 offers a variable dc offset voltage, which is controlled through the TEKPROBE™ interface by the host instrument.

The P6204 has a 1.5-meter signal cable. No power cable is necessary, as power is drawn from the host-instrument plug-in through the TEKPROBE™ interface.

The miniature probe head of the P6204 is fully compatible with the Tektronix family of miniature probe accessories.

## ACCESSORIES

The P6204 is shipped with the following standard accessories:

- 1 Instruction Manual
- 1 Hook Tip
- 2 Circuit-Board-To-Probe-Tip Adapters
- 1 Ground Lead
- 1 IC Grabber
- 1 Alligator Clip
- 1 Ground Contact
- 1 Ground Sleeve Cover
- 1 Tip, Probe, I.C. Test

Use of these accessories is described in the "Operating Instructions" section of this manual. Part numbers and optional accessories are listed in the "Replaceable Parts List" (Section 8).

## PERFORMANCE CONDITIONS

The electrical characteristics listed in Table 1-1 apply when a calibrated probe is used with a calibrated oscilloscope system operating within the environmental conditions stated in Table 1-2.

Items listed in the "Performance Requirement" column are verifiable qualitative or quantitative limits. Items listed in the "Supplemental Information" column are not verified in the "Performance Check Procedure" (Section 3); they are either explanatory notes, calibration setup descriptions, perfor-

mance characteristics for which no absolute limits are specified, or characteristics that are impractical to check.

The probe's physical characteristics are listed in Table 1-3.

**Table 1-1**  
**Electrical Characteristics**

<b>Characteristic</b>	<b>Performance Requirement</b>	<b>Supplemental Information</b>
Attenuation (system)	$10X \pm 1.5\%$ at dc.	Into a $50 \Omega \pm 0.5\%$ load. <sup>b</sup>
Input Resistance (system)	$\geq 10 \text{ M}\Omega$ at dc. <sup>a</sup>	
Input Capacitance	$\leq 1.9 \text{ pF}$ (1 kHz to 1.0 GHz). <sup>a</sup>	Typically $1.7 \text{ pF}$ . <sup>c</sup> See Figure 1-1 for a graph of input impedance versus frequency.

<sup>a</sup> Performance Requirement not checked in manual.

<sup>b</sup> Additional gain accuracy may be obtained by utilizing the probe calibrate function of the 11000 Series mainframe.

<sup>c</sup> At room temperature.

Table 1-1 (cont)

Characteristic	Performance Requirement	Supplemental Information
Bandwidth (Probe only)	DC to 1.0 GHz.	Typically 1.1 GHz. <sup>b</sup> Small signal bandwidth (See Figure 2-2).
Rise Time (Probe Only)	< 350 ps.	Small signal rise time (See Figure 2-1).
Rise Time (System)	< 490 ps. <sup>a</sup>	When used in a system w/rise time of 350 ps such as the 11A71 and 11402 (Small signal rise time. See Figure 2-1).
Aberrations (Probe Only)	± 6%, 10% p-p total for first 6 ns, ref point at 6 ns. ± 4%, 6 ns to 30 ns, ref point at 30 ns. ± 3%, 30 ns to 20 μs, ref point at 20 μs. ± 1.5%, 20 μs to dc.	When used in a system w/rise time of 350 ps such as the 11A71 and 11402.
Signal Delay	8.4 ns ± 200 ps. <sup>a</sup>	Probe tip to output connector, measured at 50% points.
Output Offset (Probe Only)	< 10 mV.	Tested at 25° C (77°F).
(following 11000 Series probe calibration)	< 2 mV	Tested at 25° C (77°F).
Linearity Error	< 2 % at dc.	(Relative to output full scale with ±10V range on input.) See <i>Input Linear Dynamic Range</i> , Section 2.

<sup>a</sup> Performance Requirement not checked in manual.

<sup>b</sup> At room temperature.

Table 1-1 (cont)

Characteristic	Performance Requirement	Supplemental Information										
DC Thermal Drift	$< 150 \mu\text{V}/^\circ\text{C}^{\text{a}}$	Equivalent output voltage.										
Output Load Requirement	$50 \Omega \pm 0.5\%^{\text{a}}$											
Maximum Nondestructive Input Voltage	40 Vdc continuous. <sup>a</sup>	See Figure 1-2.										
Electrostatic Immunity	Will withstand discharge through 1 k $\Omega$ resistance to a 500 pF capacitor charged to 10kV.	Discharge to the probe tip and the TEKPROBE™ connector pins.										
Power Supply Requirements	<table border="1"> <thead> <tr> <th>Voltage Level</th> <th>Maximum Current</th> </tr> </thead> <tbody> <tr> <td>+15 V <math>\pm</math> 2%</td> <td>29 mA</td> </tr> <tr> <td>-15 V <math>\pm</math> 2%</td> <td>33 mA</td> </tr> <tr> <td>+ 5 V <math>\pm</math> 2%</td> <td>40 mA</td> </tr> <tr> <td>- 5 V <math>\pm</math> 2%</td> <td>25 mA</td> </tr> </tbody> </table>	Voltage Level	Maximum Current	+15 V $\pm$ 2%	29 mA	-15 V $\pm$ 2%	33 mA	+ 5 V $\pm$ 2%	40 mA	- 5 V $\pm$ 2%	25 mA	<p>Power drawn from host instrument: Max. 1.25 Watts.</p> <p>Less accurate supply levels incur output offset error.</p>
Voltage Level	Maximum Current											
+15 V $\pm$ 2%	29 mA											
-15 V $\pm$ 2%	33 mA											
+ 5 V $\pm$ 2%	40 mA											
- 5 V $\pm$ 2%	25 mA											
Probe Coding	Meets TEKPROBE™ standard, Level 2.											
DC Offset Range	$\pm 15 \text{ V}$ accurate to $\pm 2\%$ ( $\pm 30 \text{ mV}$ measured at probe output).	Referenced to the probe tip.										

<sup>a</sup> Performance Requirement not checked in manual.



**Table 1-2  
Environmental Characteristics**

<b>Characteristic</b>	<b>Information</b>
Temperature Range (Operating)	0° C to + 50° C (+32° F to 122° F).
Temperature Range (Nonoperating)	- 55° C to + 75° C (- 67° F to + 167° F).
Humidity	Five cycles (120 hr.) at 90% to 95% relative humidity.
Altitude (Operating)	To 4,600 m (15,000 ft).
Transportation	Qualifies under National Safe Transit Association's Pre-shipment Test Procedures; 1A-B-1.

**Table 1-3  
Physical Characteristics**

<b>Characteristic</b>	<b>Information</b>
Net Weight (includes accessories)	680 g (1.3 lbs).
Signal Cable Length	1.5 m (60 in).

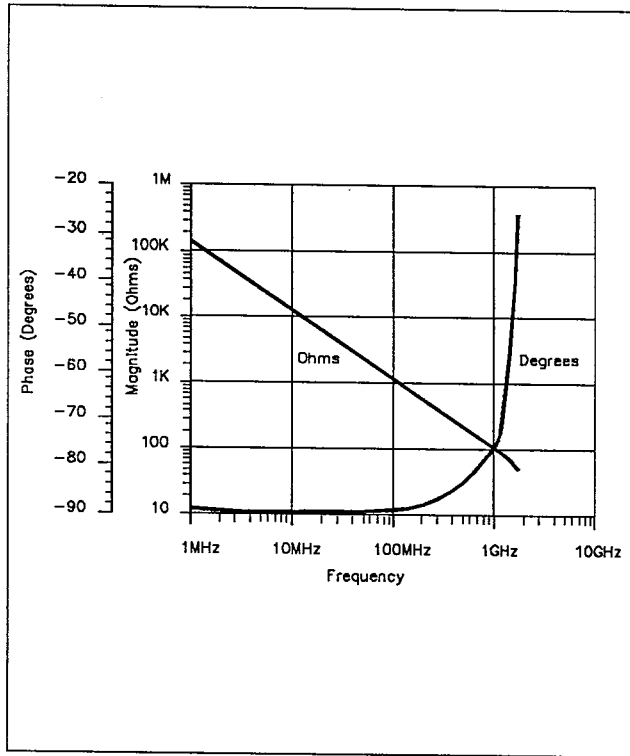

Figure 1-1. Typical Input Impedance vs frequency.

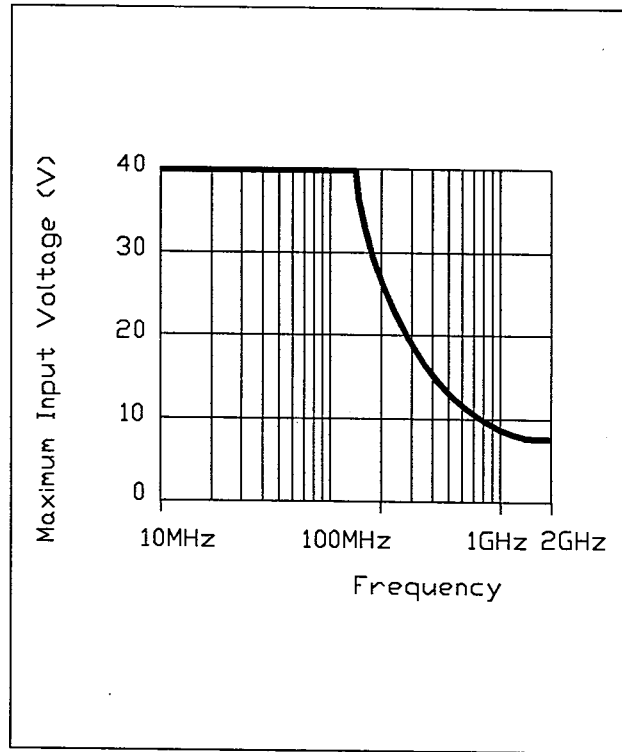

Figure 1-2. Operating voltage derating.

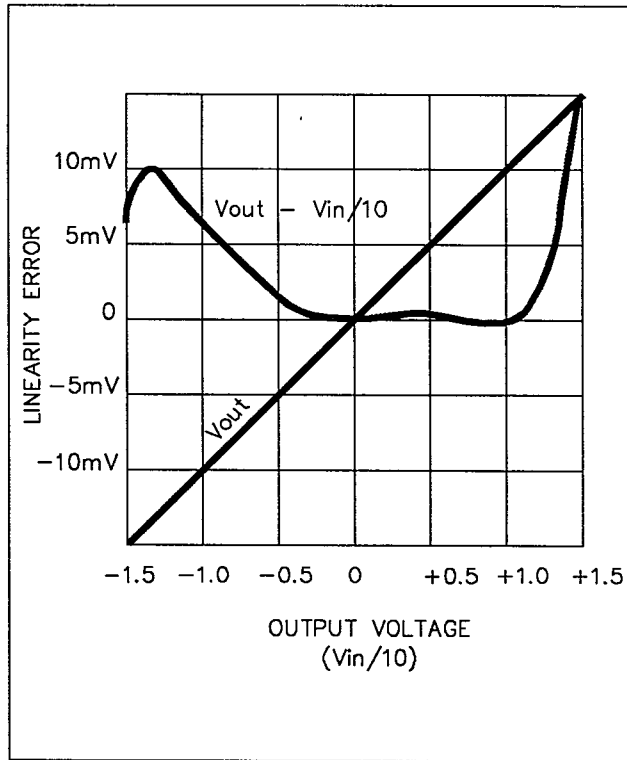
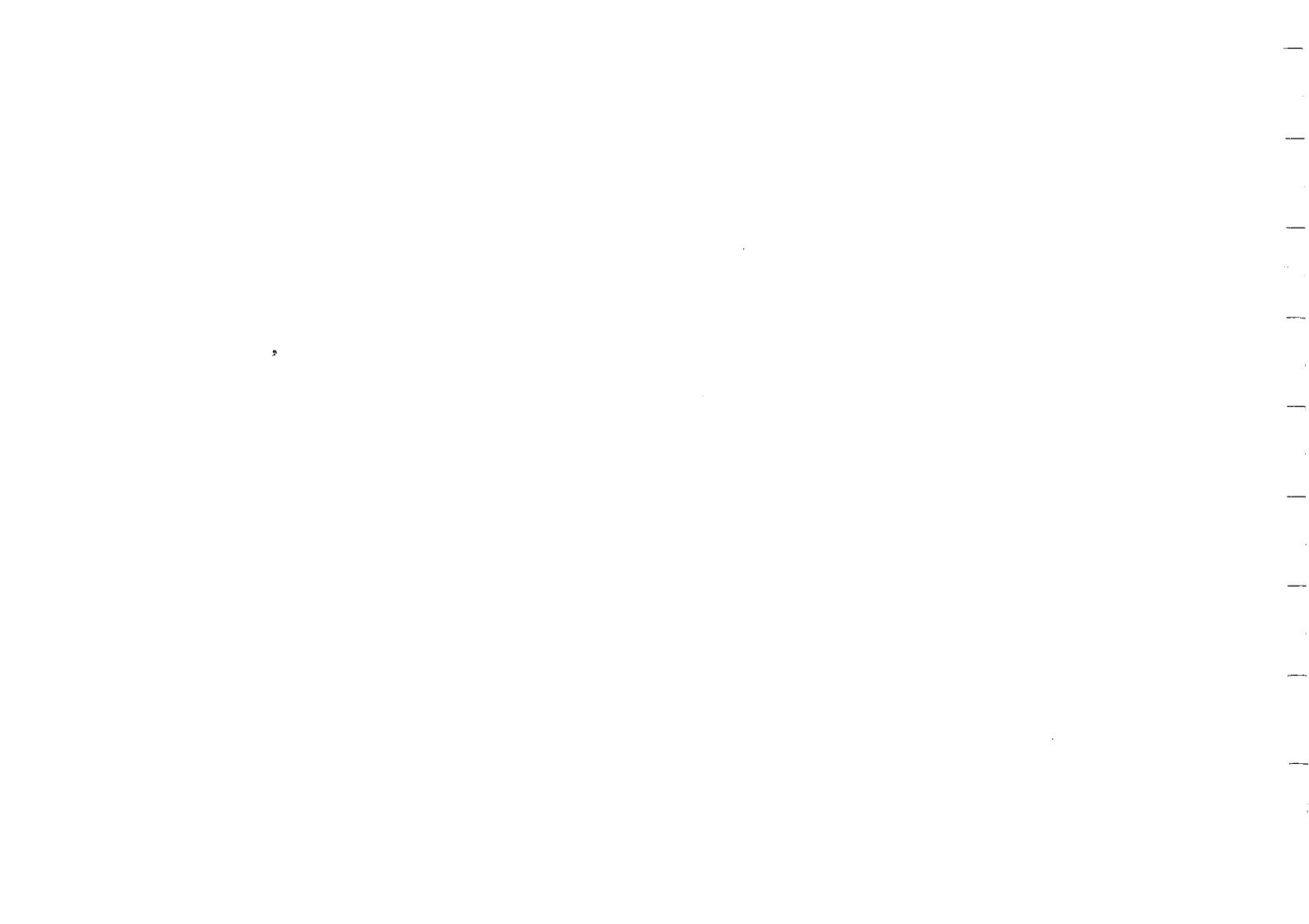

Figure 1-3. Typical Linearity Curve.



# OPERATING INSTRUCTIONS

## INTRODUCTION

This section of the manual is intended to familiarize the operator with the use of the P6204 Probe. Included are operating considerations, descriptions of the controls and connectors, and instructions for the use of the accessories.

### NOTE

*The P6204 is shipped in a carton along with its standard accessories. At installation, save the shipping carton and packaging materials for reuse should reshipment become necessary. Refer to "Maintenance" (Section 6) for further information.*

## OPERATING CONSIDERATIONS

### Probe Handling

The P6204's miniature body has been designed for ease of use when probing small circuitry. Both the probe itself and its accessories should be handled carefully at all times. To prevent damage, avoid dropping the probe body, since

damage to its tip may result. Exercise care to prevent crushing the cable or placing excessive strain on it by pulling.

### Input Linear Dynamic Range

The input linear dynamic range (< 2% error at dc) of the P6204 is limited by the ability of the internal amplifier to drive the 50  $\Omega$  termination. This limitation exists whether the input signal originates at the probe tip (test signal) or as internal offset voltage. Therefore, the limitation on the signal that can be applied to the probe tip is dependent on the amount of offset voltage being used. To maintain signal fidelity, the test signal should not exceed the limits imposed by the following formula:

$$-10.0 \text{ V} \leq (V_{\text{signal}} - V_{\text{offset voltage}}) \leq +10.0 \text{ V}$$

### High Amplitude Frequency Response

The frequency response of the P6204 is a function of input signal amplitude. As the amplitude and frequency of the input signal are increased beyond certain limits, the P6204 will begin to operate non-linearly and the frequency response will be degraded. For step inputs, this translates to slower

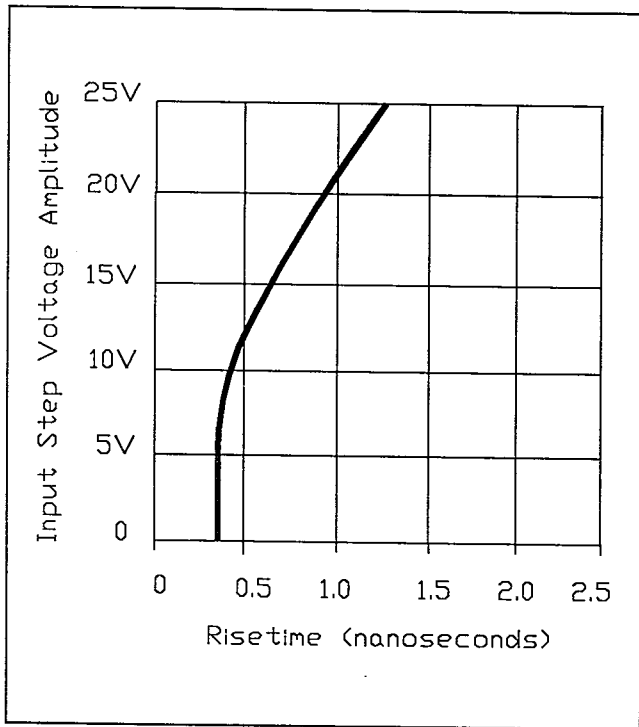

**Figure 2-1. Typical linear operating region for step inputs.**

rise times and distorted responses for high amplitude inputs. See Figure 2-1 for a plot of the linear operating region for step inputs as a function of input signal amplitude and rise time.

For sine wave inputs, the non-linearity will result in harmonic distortion and reduced peak to peak amplitude (i.e., lower -3dB bandwidth) for large amplitude, high-frequency sine wave inputs. See Figure 2-2 for a plot of -3dB bandwidth as a function of peak-to-peak sine wave input.

The high frequency performance of the probe at high amplitudes can be improved by using the offset function of the P6204. By using the offset to center the waveform of interest on the oscilloscope screen, the probe will be operating in the center of its dynamic range and the high frequency behavior of the P6204 will be improved.

### **Probe Grounding**

A probe is a capacitive divider for high-frequency signal components. Inductance introduced by either a long signal lead or ground lead will form a series-resonant circuit that can distort the true waveform or degrade the bandwidth. The ground lead and signal-input connections should be kept as short as possible to maintain the best waveform fidelity. (Refer to Figures 2-3 and 2-4.)

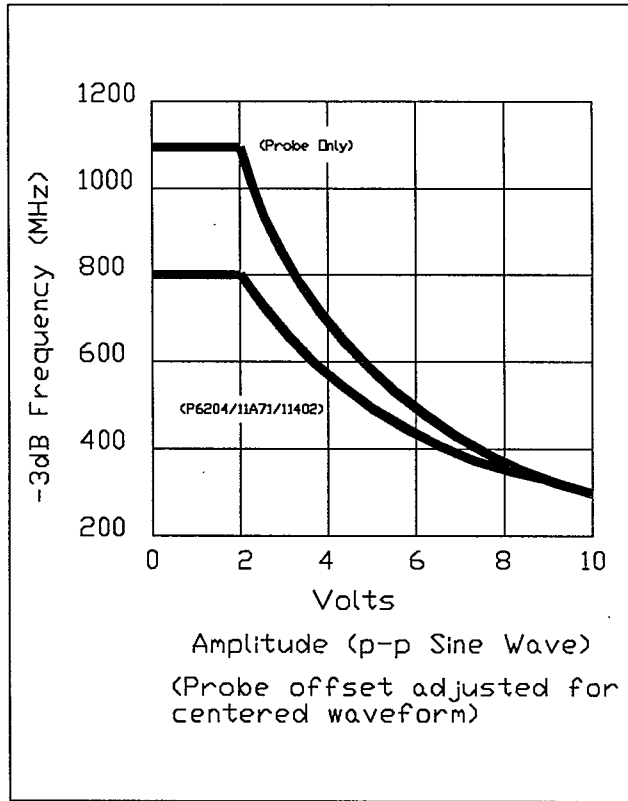
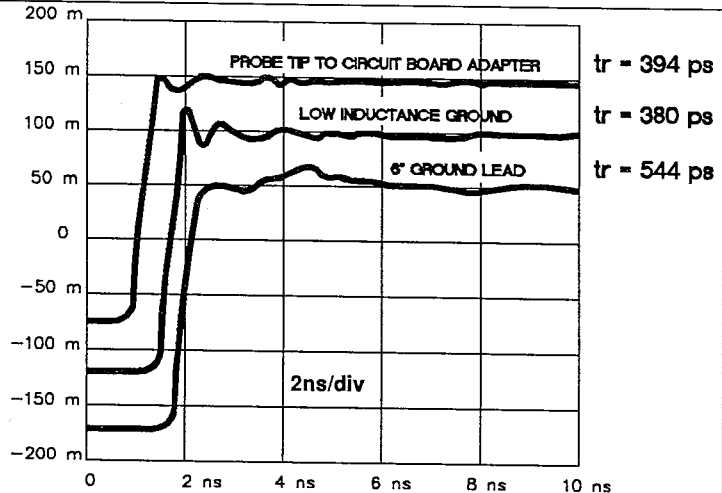
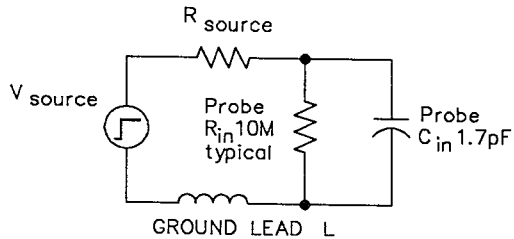

Figure 2-2. Typical -3dB frequency versus amplitude.



Ground-lead inductance can significantly reduce the performance of a probe. As shown in the model above, the ground lead inserts a series inductance into the signal path forming a series-resonant circuit between  $C_{in}$  of the probe and ground lead  $L$ , with only  $R_{source}$  and the series tip resistance as damping. This forms a resonating circuit with  $f_0 = 1 / (2\pi \sqrt{LC})$ . A six-inch ground lead has  $\approx 150$  nH of self inductance causing an  $f_0$  of 315 MHz, which is within the frequency response of the instrument. This greatly degrades risetime, bandwidth, and transient accuracy (see illustration). For best results, make sure that ground-lead inductance is at a minimum. Use of probe tip-to-circuit board adapter described on following page insures that ground lead inductance is at a minimum.

Figure 2-3. Damaging effects of ground-lead inductance.



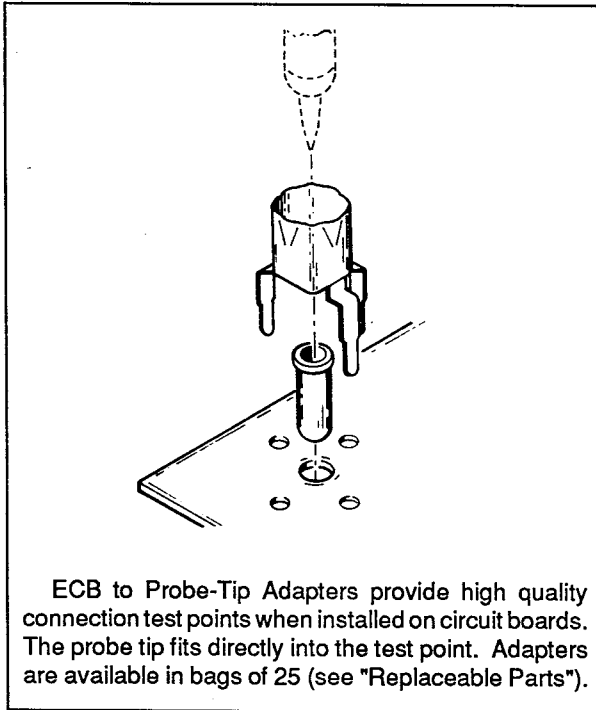

**Figure 2-4. Inductance reducing connectors.**

## DESCRIPTION OF CONTROLS AND CONNECTORS

The following information will familiarize the operator with the location and function of the external controls and connections of the P6204. Please refer to Figure 2-5.

**TEKPROBE™ Interface** - Provides connections for signal, power, and data communication between the probe and the host instrument.

**BNC Locking Ring** - Locks the probe onto the host instrument. To install, first check that the locking ring is fully counter-clockwise as viewed from the rear of the compensation box. Insert the probe onto the instrument so that the flipper slips into the notch provided for it on the front panel. To lock the probe onto the instrument, rotate the locking ring clockwise until the probe is secured to the instrument.

**ID Button** - Activates the ID function in the host instrument when pushed. If the instrument is connected to an IEEE-488 bus, an SRQ flag will be activated if the host instrument is programmed to do so.

**Probe Tip** - Used to acquire the signal from the circuit under test (replaceable probe tip).

**Ground Lead** - Can be connected to the alligator clip, the micro-hook, or directly onto a square-pin ground on a circuit board.

### PROBE ACCESSORIES

Both standard and optional accessories for the P6204 are listed in the "Replaceable Parts List" near the back of this manual. Standard accessories are supplied to aid in connecting the probe to circuitry under test and to protect the probe against damage. These accessories are described in the following paragraphs and are illustrated in Figure 2-5.

#### Ground Leads

The P6204 Probe is supplied with two ground-lead systems: a ground collar with integral lead and a low-inductance ground collar/lead. The collar with integral lead features a 6 inch-lead length which is attachable to an alligator clip, a IC Grabber, or directly to a square-pin connector on the circuit board. The low inductance ground lead fits directly over the probe tip ground ring. Refer to the information on *DAMAGING EFFECTS OF GROUND LEAD INDUCTANCE* (provided in this section), to assist you in making the best selection of a ground-lead system.

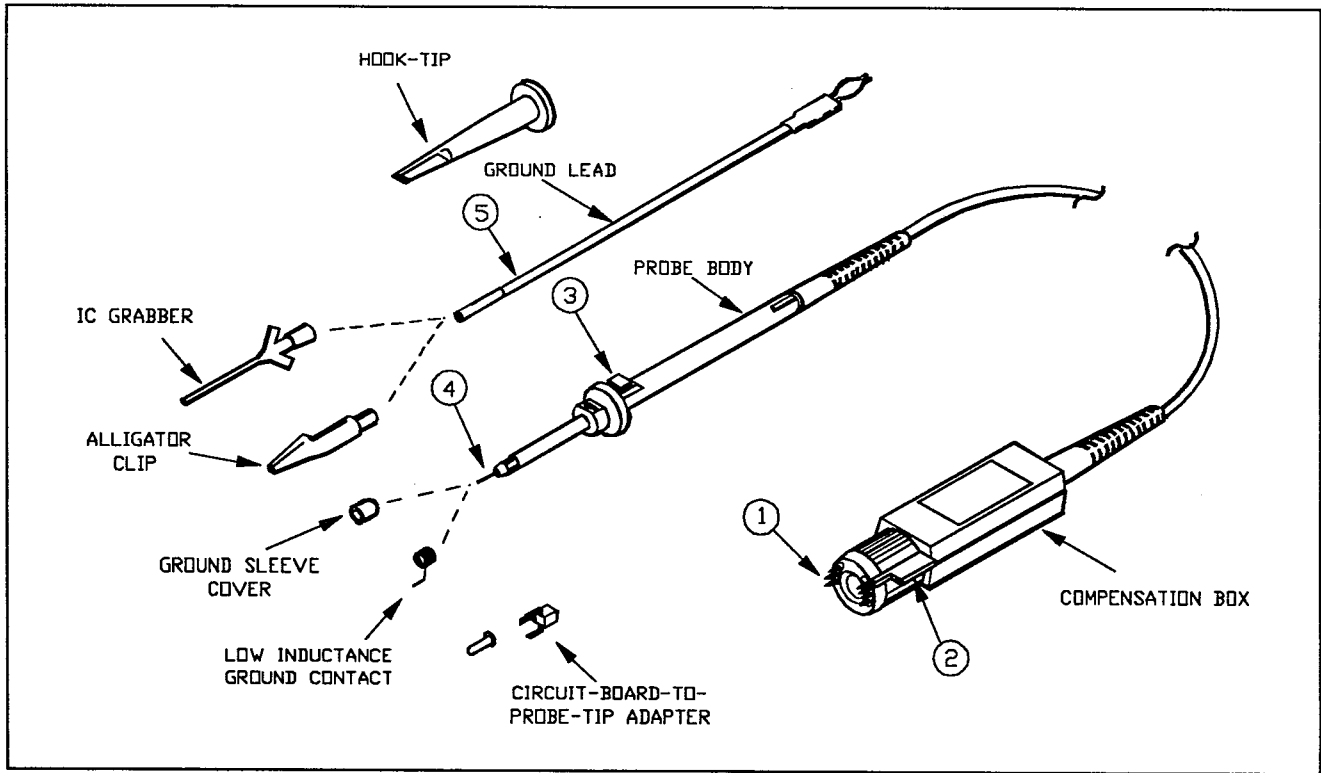

Figure 2-5. Controls, connectors and probe accessories.

## Circuit-Board-to-Probe-Tip Connectors

Two circuit-board-to-probe-tip connectors are provided for making permanent probe test points on circuit boards. These connectors provide extremely short signal and ground paths to minimize ringing.

### Hook Tip

The hook tip provides the means for making a hands-free connection to a test point or component lead. To install the hook tip, just slide the hook tip onto the probe.

### Carrying Box

The carrying box (not shown) provides a convenient means to store and protect the P6204, its accessories, and this manual when they are not in use.

## Use With Other Oscilloscopes

The TEKTRONIX 1103 TEKPROBE™ Power Supply enables the P6204 to be used with TEKTRONIX 7000 Series oscilloscopes or other oscilloscopes not equipped with the TEKPROBE™ interface. The 1103 TEKPROBE™ Power Supply is an external power supply that is equipped with the TEKPROBE™ interface and has a conventional BNC output signal connector. (The cable used to connect the output of the 1103 to the oscilloscope should be kept as short as possible to insure that the high frequency response of the P6204 is not degraded). The 1103 supplies power and the DC offset function for two probes, however, the ID function, attenuation indication and data communications between the probe and scope are not operable.

# PERFORMANCE CHECK PROCEDURE

## PURPOSE

The "Performance Check Procedure" is used to verify the probe's Performance Requirements as listed in "Specification" (Section 1) and to determine the need for readjustment. This procedure may also be used both as an acceptance check and as a test of the probe after repair.

## TEST EQUIPMENT REQUIRED

The test equipment listed in Table 3-1 is a complete list of equipment required to accomplish the "Performance Check Procedure." Test equipment specifications described in Table 3-1 are the minimum necessary to provide accurate results; therefore, equipment used must meet or exceed the listed specifications. Detailed operating instructions for test equipment are not contained in this procedure. Should additional operating information be needed, refer to the appropriate test-equipment instruction manual.

## LIMITS AND TOLERANCES

The limits and tolerances given in this procedure are for the P6204 under test only. Test-equipment error is not included except as noted.

## PREPARATION

Before proceeding with this check, allow sufficient warm-up time for test equipment to stabilize (typically 20 minutes).

**Table 3-1**  
**Test Equipment Required**

Item Number and Description	Minimum Specification	Purpose	Example of Suitable Test Equipment
1. Oscilloscope	Bandwidth: dc to 1 GHz. Vertical deflection factor: 10 mV to 1 V. 1M $\Omega$ input and full bandwidth 50 $\Omega$ input.	Offset range check. Attenuation check. HF checks.	TEKTRONIX 11402 with 11A71 and 11A32 or 11A34.
2. Digital Multimeter	DC volts accuracy: 0.1%	Offset range check.	TEKTRONIX DM 502A.
3. DC Voltage Source	Output: + and - 15 V.	Offset range check.	TEKTRONIX PS 503A.
4. Calibration Generator	Amplitude accuracy: $\pm$ 0.25%	Attenuation check.	TEKTRONIX PG 506.
5. Pulse Generator	Rise time: less than 100 ps.	HF checks.	TEKTRONIX 284, or S-52 in a 7S12.
6. Termination Adapter	Impedance: 50 $\Omega$ . Connectors: miniature probe tip-to-GR.	HF checks. Attenuation Checks.	Tektronix Part Number 017-0088-00.
7. Adapter: Male BNC-to-GR.	Connectors: BNC-to-GR	HF Checks. Attenuation Checks.	Tektronix Part Number 017-0064-00.
8. Precision Coaxial Cable	Impedance: 50 $\Omega$ Length: 36 in. Connectors: BNC	HF Checks. Attenuation Checks.	Tektronix Part Number 012-0482-00.
9. BNC-T		Attenuation Checks.	Tektronix Part Number 103-0030-00.
10. Adapter: Female BNC-to-GR		HF Checks.	Tektronix Part Number 017-0063-00.
11. Adjustment tool		Offset and attenuation.	Tektronix Part Number 003-1416-00.

## PROCEDURE STEPS

### 1. Output Zero Check

#### Equipment Required (see Table 3-1):

Oscilloscope (Item 1)

a. Connect the probe to an 11A71 plug-in on an 11402 Oscilloscope mainframe.

b. Set the oscilloscope controls as follows:

Volts/Division	100 mV
Input Coupling	DC
Time/Division	1 ms
Trigger Source	Channel Used
Trigger Mode	Auto Level
Coupling	DC

c. Set the oscilloscope vertical offset to 0.0 volts.

d. Touch the probe input to a convenient ground point on the test oscilloscope.

e. CHECK — That the trace is within 1.0 divisions (0.2 divisions after probe calibration function of 11000 Series plugin/mainframe) of the center horizontal graticule line. If it is not, refer to the "Output Zero" adjustment procedure.

### 2. DC Offset Range Check

#### Equipment Required (see Table 3-1):

Oscilloscope (Item 1)  
Digital Multimeter (Item 2)  
DC Voltage source (Item 3)

a. Connect the probe to an 11A71 plug-in in an 11402 Oscilloscope mainframe.

b. Set the oscilloscope controls as follows:

Volts/Division	5 Volts
Input Coupling	DC
Time/Division	1 ms
Trigger Source	Channel Used
Trigger Mode	Auto Level
Coupling	DC

c. Set the oscilloscope vertical offset to 0.0 Volts.

d. Touch the probe input to a convenient ground point on the test oscilloscope.

e. CHECK — That the VERTICAL OFFSET control on the oscilloscope is able to vertically position the trace over a +15 V to -15 V range. If it is not refer to the "Offset Range" Adjustment Procedure.

f. Set vertical sensitivity to 100 mV/div.

g. Record the offset with probe tip grounded.

h. Using multimeter to confirm, adjust the variable DC voltage source (PS 503) to +15 V.

i. Connect the probe ground (through a probe ground lead) to the voltage source ground output, and the probe input to the + voltage source.

j. Adjust the oscilloscope offset to +5 V.

k. Check that the trace is within  $\pm 300$  mV of the center horizontal graticule line (less the offset recorded in step g.)

### 3. Attenuation Accuracy

#### Equipment Required (see Table 3-1):

Oscilloscope with 11A32 or 11A34 (Item 1)

Calibration Generator (Item 4)  
Termination Adapter (Item 6)  
BNC-to-GR Adapter (Item 7)  
BNC-T (Item 9)  
Precision Coaxial Cable (Item 8)

a. Connect cable to Fast Rise output of calibration generator. Connect BNC-T to opposite end of cable. Connect terminator adapter and BNC-to-GR adapter to BNC-T. Connect BNC-T to 11A32 channel.

b. Set the oscilloscope controls as follows:

Volts/Division	100 mV
Time/Division	20 $\mu$ s
Trigger Select	Main
Trigger Source	Channel Used
Trigger Mode	Auto Level
Coupling	DC

c. Set calibration generator frequency to 10 kHz.

d. Adjust variable amplitude for 10 vertical divisions on screen.

e. Remove BNC-T from 11A32.

f. Connect probe to 11A32 channel used.



- g. Insert probe tip into termination adapter.
- h. Set vertical sensitivity to 100 mV/division.
- i. CHECK that the first 20  $\mu$ s are 10 vertical divisions  $\pm 0.3$  divisions.

**NOTE**

*Additional accuracy may be obtained by multiplying the waveform in the Vertical Description Mode and averaging.*

- j. CHECK for 10 vertical divisions  $\pm 0.15$  divisions after 20  $\mu$ s.

**4. Bandwidth, Risetime and HF Aberrations Check**

**Equipment Required (see Table 3-1):**

Oscilloscope with 11A71 (Item 1)  
 Pulse Generator (Item 5)  
 Termination Adapter (Item 6)  
 Coaxial Cable (Item 8)

- a. Connect pulse generator to the 11A71 using the coaxial cable.

- b. Set oscilloscope controls as follows:

Volts/Division	50 mV/division
Input Coupling	DC
Time/Division	1 ns
Trigger Source	Channel Used
Trigger Mode	Auto Level
Trigger Select	Main
Slope	Positive

- c. Adjust the oscilloscope horizontal position control to place the 90% point of the pulse on the first division mark.
- d. Average, store and recall waveform.
- e. Measure risetime and note system aberrations.
- f. Remove the coaxial cable from the 11A71.
- g. Connect termination adapter to coaxial cable.
- h. Connect probe to 11A71 and insert probe tip into the termination adapter.
- i. Adjust the oscilloscope horizontal position control to place the 90% point of the pulse on the first division mark.
- j. Average, store and recall waveform.

k. Touch vertical description icon Vertical Desc then:

l. Touch \* 2 Enter Desc to

magnify the vertical sensitivity by a factor of two.

m. Measure risetime and aberrations of both stored waveforms.

n. Calculate probe risetime using the following formula:

Probe risetime =

$$\sqrt{(\text{measured risetime})^2 - (\text{oscilloscope system risetime})^2}$$

**NOTE**

*This calculation is only an approximation. The ac-*

*curacy of the approximation is better on faster oscilloscope systems. For optimum results use a fast sampling system such as a TEKTRONIX 7000 Series oscilloscope with 7S12 plug-in, S-6 sampling head, and S-52 pulse generator in conjunction with the 1103 probe power supply.*

o. CHECK that the probe only risetime is less than 350 ps.

p. Measure combined probe and system aberrations.

q. Measure the system aberrations.

r. Probe aberrations will be approximately the difference of the preceding two measurements. CHECK that these probe aberrations do not exceed  $\pm 6\%$ , 10% p-p.

# ADJUSTMENT PROCEDURE

## PURPOSE

This section contains the information necessary to perform the output zero, offset range, and attenuation accuracy adjustments for the P6204 Probe. The adjustment procedures are not intended to be troubleshooting guides, however, any deficiency found during performance of each adjustment step should be corrected before continuing. Tektronix Field Service Centers and the Factory Service Center provide instrument repair and adjustment service. Refer to "Maintenance" (Section 6) for further repair information.

## TEST EQUIPMENT REQUIRED

The test equipment listed in Table 3-1 is a complete list of equipment required to accomplish the "Adjustment Procedures." Test equipment specifications described in Table 3-1 are the minimum necessary to provide accurate results; therefore, equipment used must meet or exceed the listed specifications. Detailed operating instructions for test equipment are not contained in this procedure. Should additional operating information be needed, refer to the appropriate test-equipment instruction manual.

## ADJUSTMENT SEQUENCE

Because of adjustment interaction, the adjustment steps must be performed in the order given.

## ADJUSTMENT LOCATIONS

Adjustable component locations are shown in Figure 4-1. Only the adjustable components are illustrated in this figure.

## PREPARATION

Before proceeding with each adjustment step, allow sufficient warm-up time for test equipment to stabilize (typically 20 minutes).

It is necessary to remove the top half of the Control Box cover to perform the Adjustment Procedure. Refer to the removal instructions in "Maintenance" (Section 6).

## PROCEDURE STEPS

### 1. Adjust Output Zero

#### Equipment Required (see Table 3-1):

Oscilloscope (Item 1)  
Adjustment Tool (Item 9)

- a. Connect the probe to an 11A71 plug-in in an 11402 mainframe.
- b. Set test oscilloscope controls as follows:

Volts/Division	100 mV
Input Coupling	DC
Time/Division	1 ms
Trigger Source	Channel Used
Trigger Mode	Auto Level
Coupling	DC

- c. Set the oscilloscope vertical offset to 0.0 Volts.
- d. Touch the probe tip to a convenient ground point on the test oscilloscope.

- e. ADJUST — R1013 to move the trace to the center horizontal graticule line.

### 2. Adjust Offset Range

#### Equipment Required (see Table 3-1):

Oscilloscope (Item 1)  
DC Voltage Source (Item 3)  
DC Multimeter (Item 2)  
Adjustment Tool (Item 11)

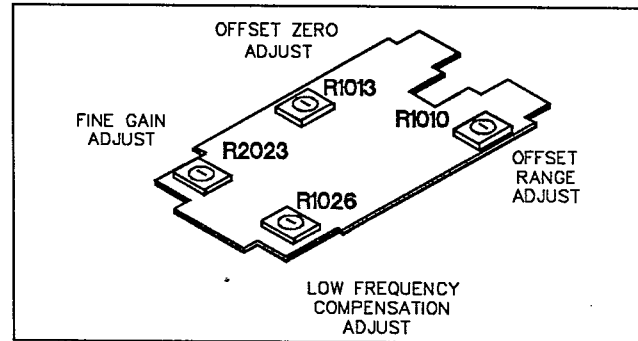

Figure 4-1. Compensation box adjustment locations.

- a. Connect the probe to an 11A71 plug-in in an 11402 Oscilloscope mainframe.

b. Set test oscilloscope controls as follows:

Volts/Division	100 mV
Input Coupling	DC
Time/Division	1 ms
Trigger Source	Channel Used
Trigger Mode	Auto Level
Coupling	DC

c. Touch the probe input to a convenient ground.

d. Record the offset with the probe trip grounded.

e. Set the oscilloscope vertical offset to 15.0 Volts.

f. Using the multimeter to confirm, adjust the variable dc voltage source (PS503) to +15 Volts.

g. Connect the probe ground (through a ground lead), to the voltage source common output. Touch the probe input to the voltage source + output.

h. ADJUST — R1010, *Offset Range Adjust*, to move the trace to the position recorded in step c. (horizontal graticule if zero probe offset).

### 3. Adjust Output Zero

Some interaction exists between the Output Zero and

Offset Range Adjustments. Repeat step 1 (Adjust Output Zero) to achieve optimum adjustment of the output zero.

### 4. Adjust Attenuation Accuracy

#### Equipment Required (see Table 3-1):

- Oscilloscope with 11A32 or 11A34 (Item 1)
- Calibration Generator (Item 4)
- Termination Adapter (Item 6)
- BNC-to-GR Adapter (Item 7)
- BNC-T (Item 9)
- Precision Coaxial Cable (Item 8)

a. Connect cable to Fast Rise output of calibration generator. Connect BNC-T to opposite end of cable. Connect termination adapter and BNC-to-GR adapter to BNC-T. Connect BNC T to 11A32 channel.

b. Set the oscilloscope controls as follows:

Volts/Division	100 mV
Time/Division	20 ms
Trigger Select	Main
Trigger Source	Channel Used
Trigger Mode	Auto Level
Coupling	DC

- c. Set calibration generator frequency to 10 kHz.
- d. Adjust variable amplitude for 10 divisions on screen.
- e. Remove BNC-T from 11A32.
- f. Connect Probe to 11A32 channel used.
- g. Insert probe tip into termination adapter.
- h. Set vertical sensitivity to 100 mV/division.

i. Adjust R1026, *Low Frequency Compensation Adjust*, for maximum response flatness in the first 20  $\mu$ s.

j. Adjust R2023, *Fine Gain Adjust*, for a 10 division waveform.

**NOTE**

*The two adjustments directly above interact, thus an optimum response may require repeating related steps until the best trade-off is achieved.*

# THEORY OF OPERATION

## INTRODUCTION

This section contains a functional description of the circuitry used in the P6204 Probe. The schematic diagram in "Replaceable Parts" (Section 8 of this manual), may be useful when reading the detailed circuit description. A functional block diagram is also provided (Figure 5-1).

## CIRCUIT DESCRIPTION

### PROBE HEAD

The hybrid assembly in the probe contains a high impedance attenuator and a high frequency unity gain FET buffer. The active buffer circuit consists of a bootstrapped FET input stage and a complementary bipolar (npn/pnp) transistor output stage.

The input FET Q1A is a source follower of which the drain bias voltage accurately tracks the changes in input gate voltage so that the drain-to-source voltage is constant with input signal changes. The bias current for Q1A FET is set by the matching FET Q1B through a common base transistor

U1(X2). By maintaining the same relative bias voltages and using Q1B to set the current in Q1A, good temperature tracking and high linearity is achieved in the FET input state.

The output stage achieves good linearity by using a complementary bipolar emitter follower transistor pair U1(X5) (npn) and Q2 (pnp).

The schematic shown for the integrated circuit is a simplified version of the actual IC. The actual IC contains 51 transistors, 39 resistors and 2 capacitors.

## COMPENSATION BOX

### MAIN CIRCUIT BOARD

U1010 is configured as a non-inverting amplifier used to increase the signal range of the offset voltage available from the TEKPROBE™ interface for use by the probe head. The variable resistor R1010 is the fine adjustment to calibrate the offset voltage scale factor.

R1013 is the offset zero potentiometer which sets a relatively small bias current level into U1010's inverting input through a high value resistor.

The U1020 circuit is set up to feed back a small amount of the output signal to the probe head attenuator. R1026 allows the feedback to be adjusted either slightly positive or slightly negative; thus adding to or subtracting a small low-frequency error signal from the probe's input signal. R1026 is adjusted to match the probe's DC and low-frequency gain

to the inherent high-frequency gain of the probe head; thus giving an overall flat response to a step voltage input to the probe.

R2023 is to provide a fine gain adjustment for the probe's DC-to-high-frequency response.

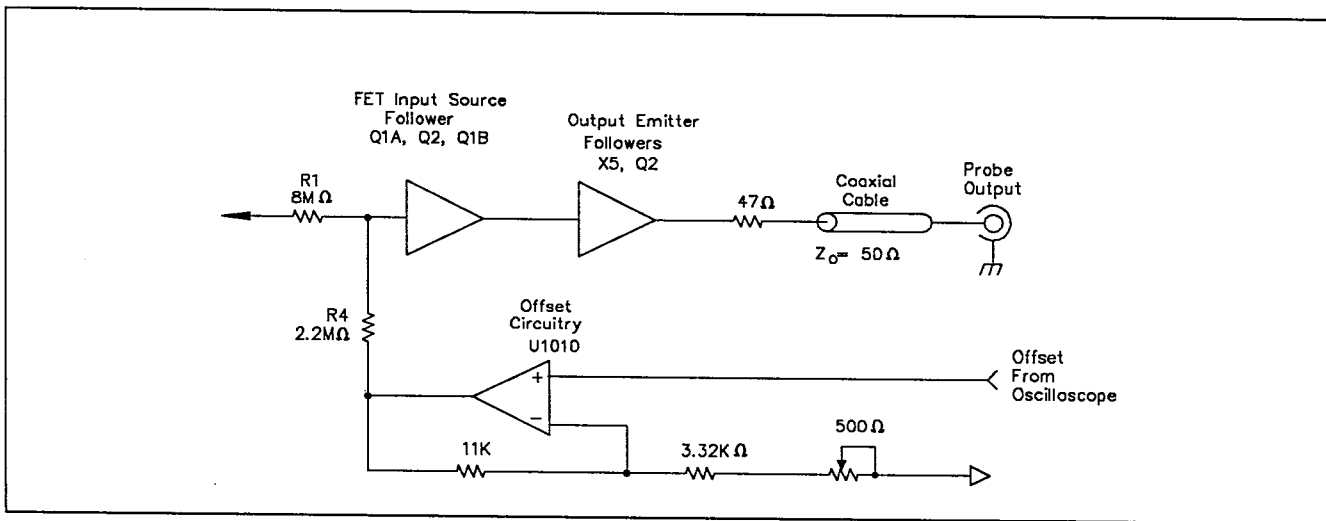

Figure 5-1. Functional block diagram.



# MAINTENANCE

## INTRODUCTION

This section contains information for performing preventive maintenance, troubleshooting, and corrective maintenance on the P6204 Probe.

## STATIC-SENSITIVE COMPONENTS



*Static discharge can damage any semiconductor component in this probe.*

This probe contains electrical components that are susceptible to damage from static discharge. See Table 6-1 for relative susceptibility of various classes of semiconductors. Static voltages of 1 kV to 30 kV are common in unprotected environments. The P6204 will withstand discharge through 1k $\Omega$  resistance of a 500pF capacitor charged to 10kV.

Table 6-1

Relative Susceptibility to Static Discharge Damage

Semiconductor Classes	Approximate Susceptibility Level <sup>a</sup>
MOS or CMOS (most sensitive)	100-500 V.
ECL	200-500 V.
Schottky signal diodes	250 V.
Schottky TTL	500 V.
High-Frequency bipolar transistors	400-600 V.
JFET	600-800 V.
Linear microcircuits	400-1,000 V.
Low-power Schottky TTL	900 V.
TTL (least sensitive)	1,200 V.

<sup>a</sup> Voltage discharged from a 100 pF capacitor through a 100  $\Omega$  resistor.

Observe the following standard precautions to avoid damage:

1. Minimize handling of static-sensitive components.
2. Transport and store static-sensitive components or assemblies in their original containers, on a metal rail, or on conductive foam. Label any package that contains static-sensitive assemblies or components.
3. Discharge the static electricity from your body by wearing a wrist strap while handling these components. Servicing static-sensitive assemblies or components should be performed only at a static-free work station by qualified service personnel.
4. Nothing capable of generating or holding a static charge should be allowed on the work station surface.
5. Keep the component leads shorted together, whenever possible, with a shorting wire or conductive foam.
6. Pick up components by the body, never by the leads.
7. Do not slide the components over any surface.
8. Avoid handling components in areas that have a floor or work-surface covering capable of generating a static charge.
9. Use a soldering iron that is connected to earth ground.
10. Use only special antistatic suction-type or antistatic wick-type desoldering tools.

# PREVENTIVE MAINTENANCE

Preventive maintenance consists primarily of cleaning and visual inspection. When performed on a regular basis, preventive maintenance can prevent instrument breakdown and may improve instrument reliability. The frequency of maintenance depends on the severity of the environment to which the probe is subjected. A convenient time to perform preventive maintenance is just before performing an Adjustment Procedure.

## CLEANING



*Avoid the use of chemical cleaning agents which may damage the plastics and circuit board used in the probe. In particular, avoid chemicals which contain benzene, toluene, xylene, acetone, or similar solvents. For additional information on recommended cleaning agents, consult your Tektronix Service Center or representative.*

## Exterior

Loose dust accumulated on the outside of the probe can be removed with a soft cloth or a small brush. Dirt which remains can be removed with a soft cloth dampened in a mild detergent and water solution. Do not use abrasive cleaners.

## Interior

Cleaning the interior of the probe should not be necessary. Normally, the probe circuit boards will not require cleaning unless a cover has been removed for an extended period of time. The best way to clean the interior is to blow off the accumulated dust with dry, low-velocity air (about 9 lb/sq. in). Remove any dirt which remains with a soft brush or a cloth dampened with a nonresidue-type cleaner, preferably isopropyl alcohol. A cotton-tipped applicator is useful for cleaning in narrow spaces or for cleaning more delicate circuit components.

## **VISUAL INSPECTION**

Occasionally inspect the P6204 for such defects as broken connections, damaged parts, bent leads, and heat-damaged components. Overheating usually indicates other trouble in the probe, therefore, the cause of overheating must be corrected to prevent recurrence of the damage.

## **SEMICONDUCTOR CHECKS**

Periodic checking of semiconductors is not recommended. The best check of semiconductor performance is proper operation of the probe.

# TROUBLESHOOTING

The following information is provided to facilitate troubleshooting the P6204. An understanding of circuit operation is often helpful in locating troubles. Refer to "Theory of Operation" (Section 5) for this information.

the P6204. If the particular items listed are not available, substitutions may be made with similar test equipment which meet or exceed the listed specifications.

Table 6-2 lists the equipment useful for troubleshooting

Table 6-3 is a listing of possible fault indications and their probable causes.

**Table 6-2**  
**Troubleshooting Equipment**

<b>Description</b>	<b>Minimum Specification</b>	<b>Example</b>
1. Real Time Oscilloscope	Bandwidth: dc to about 1 GHz. Vertical deflection factor: 10 mV to 1 V.	TEKTRONIX 11402 with 11A71 plug-in.
2. Digital Multimeter	Voltmeter: 0 to 20 V dc range, 0.15% accuracy. Ohmmeter: 0 to 2 M $\Omega$ range.	TEKTRONIX DM 502A.

**Table 6-3  
Fault Indication and Probable Cause**

<b>Fault Indication</b>	<b>Probable Cause</b>	<b>Corrective Action</b>
Wrong Attenuation Ratio.	<ol style="list-style-type: none"> <li>1. Defective probe head assembly.</li> <li>2. Input signal exceeds probe dynamic range.</li> </ol>	<p>Replace probe head assembly.</p> <p>Reduce signal amplitude to specification limits.</p>
Low-Frequency Compensation or HF Attenuation (First 30 ns of Transition Response) Error.	<ol style="list-style-type: none"> <li>1. Defective probe head assembly.</li> </ol>	<p>Replace probe head assembly.</p>
Risetime out of Specification or Excessive HF Aberrations.	<ol style="list-style-type: none"> <li>1. Defective probe head assembly.</li> </ol>	<p>Replace probe head assembly.</p>
DC Output Zero out of specification.	<ol style="list-style-type: none"> <li>1. R1013 misadjusted.</li> <li>2. Defective power supply.</li> <li>3. Broken or unsoldered wire, connection, or component.</li> </ol>	<p>See "Adjustment Procedure."</p> <p>Check-power supply fuses in oscilloscope plug-in. Visually check for damage and repair any found.</p>

**Table 6-3 (contd)  
Fault Indication and Probable Cause**

<b>Fault Indication</b>	<b>Probable Cause</b>	<b>Corrective Action</b>
No Signal or Intermittent.	<ol style="list-style-type: none"> <li>1. Broken or unsoldered wire, connection, or component.</li> <li>2. Defective cable assembly.</li> <li>3. Signal path shorted to ground.</li> <li>4. Defective probe-head assembly.</li> </ol>	<p>Visually check for damage and repair any found.</p> <p>Check for shorts or opens and replace if necessary.</p> <p>Visually check all probe cable connectors and circuit board connectors. Repair or replace if necessary.</p> <p>Replace probe head assembly.</p>
Instrument Does Not Respond to ID Switch.	<ol style="list-style-type: none"> <li>1. Defective ID button.</li> <li>2. Open cable.</li> <li>3. Broken TEKPROBE™ Interface pin.</li> </ol>	<p>Replace probe head assembly.</p> <p>Replace Cable.</p> <p>Replace pin.</p>

**Table 6-3 (contd)  
Fault Indication and Probable Cause**

<b>Fault Indication</b>	<b>Probable Cause</b>	<b>Corrective Action</b>
Offset Voltage Feature Does Not Work or is Out of Specification.	<ol style="list-style-type: none"> <li>1. R1010 misadjusted.</li> <li>2. U1 defective.</li> <li>3. Open cable.</li> <li>4. Broken TEKPROBE™ Interface pin.</li> </ol>	<p>See adjustment procedure.</p> <p>Replace main circuit board.</p> <p>Replace cable.</p> <p>Replace pin.</p>
Oscilloscope Does Not Respond to Installed Probe.	<ol style="list-style-type: none"> <li>1. Broken TEKPROBE™ Interface pin.</li> <li>2. ROM damaged.</li> </ol>	<p>Replace pin.</p> <p>Replace flexible circuit board assembly.</p>



## TROUBLESHOOTING TECHNIQUES

The following techniques are arranged in an order that checks the simple possibilities before proceeding with extensive troubleshooting. The first few checks ensure proper connection, operation and calibration. If the trouble is not located by these checks, the remaining steps should aid in isolating a defective component. Replace defective components using the "Corrective Maintenance" procedures in this section.

### 1. Check Control Settings

Incorrect control settings can indicate a trouble that does not exist. If there is any question about the correct function or operation of any control, refer to Section 2, "Operating Instructions."

### 2. Check Associated Equipment

Associated equipment at either input or output of the probe may be defective. A signal you expect to see might not exist or might be distorted at the point you are testing. If

you are using the probe with an oscilloscope, the vertical amplifier may be defective or the vertical controls may be misadjusted.

### 3. Check Calibration

An out-of-calibration condition of either oscilloscope or probe can cause an apparent error in a measurement.

### 4. Make Visual Checks

Many problems can be located visually. Check for broken wires, damaged connections, or damaged circuit boards. If you discover a heat-damaged component, find the cause of overheating to prevent recurrence of the problem.

### 5. Refer to Troubleshooting Chart

Table 6-3 lists possible malfunctions and their probable causes.

### 6. Check Waveforms and Voltages.

Schematic and component layout diagrams are provided in Section 7.

# CORRECTIVE MAINTENANCE

Corrective maintenance consists of replacing a defective component or assembly. Special techniques required to do so are given here.

## MAINTENANCE PRECAUTIONS

To reduce the possibility of personal injury or probe damage, observe the following precautions:

### **WARNING**

*To prevent electrical shock or shorting components, do not perform probe maintenance while the probe is connected to a power source.*

### **NOTE**

*Because the P6204 is constructed with a hybrid and surface mounted components which are not easily removed or resoldered, replacement of individual components is not recommended. For assured performance, replace circuit boards as a completely pretested unit.*

## OBTAINING REPLACEMENT PARTS

### **Special Part**

Most of the parts and assemblies in this probe are specifically made or selected by Tektronix, Inc. to meet specific performance requirements. Order all parts directly from your local Tektronix Field Office or representative.

### **Ordering Parts**

When ordering and to insure receiving the proper parts or assemblies, include all of the following information with your order:

1. Instrument type (including modification or option numbers).
2. Description of the part (if electrical, include the circuit or assembly number).
3. The Tektronix part number.

## ASSEMBLY REPLACEMENT

### Probe Tip Replacement

To replace the probe tip, simply unscrew the old tip and replace it with a new tip.

### Probe Head Replacement

#### NOTE

*A schematic on the probe head hybrid and IC is provided in section 7 for your information. This hybrid is not accessible and individual parts cannot be replaced.*

To replace the probe head assembly (which includes the probe tip hybrid assembly), grasp the cable in one hand and the probe head assembly in the other, and pull straight apart. To install the new probe head assembly, align the slot on the probe head with the key on the cable assembly boot, and push the two together using a slight back-and-forth movement to seat the connectors together, without using excessive force.

### TEKPROBE™ Contact Pin Replacement

To replace a contact pin, carefully grasp the end of the pin

to be replaced with a pair of needle-nosed pliers and pull it straight out of the BNC assembly (refer to Figure 6-2).

To install a new pin, carefully hold the pin with needle nosed pliers and push the pin into the BNC assembly. Be careful not to bend or crush the pin.

### Compensation Box Disassembly

#### WARNING

*To prevent electric shock or shorting of components, disconnect the power connector from the power source before removing the covers from the compensation box.*

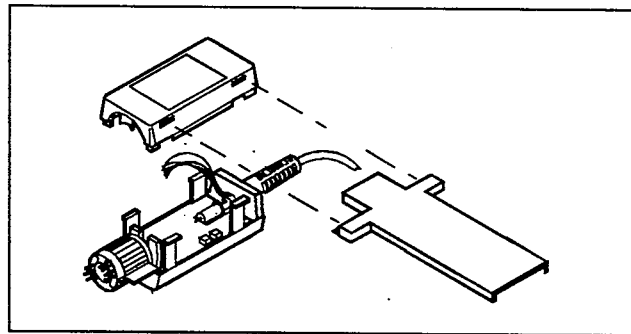

Figure 6-1. Compensation box disassembly.

The following procedure should be used when replacing assemblies in the compensation box (refer to Figure 6-1).

a. Insert tool 003-1383-00 (optional) into the slots near the top of the compensation box, pressing firmly on both tabs while prying upwards on the box half parting line to separate the halves.

b. Hold the halves apart while repeating the procedure on the other side. Gently work the top half off the compensation box while holding the cable-boot assembly and the BNC assembly firmly in the bottom box half.



*Failure to hold the cable boot and BNC assemblies in the bottom box-half while disassembling may result in damage to the flexible circuit board which resides below the main-board and connects it to the BNC assembly.*

### Cable Assembly Replacement

The cable is replaceable as a complete assembly. To replace the cable assembly, first follow the steps given to remove the probe head and to disassemble the compensation box. Then proceed as follows:

a. Unsolder and identify for later installation the four power cable wires from the main circuit board (refer to Figure 7-4).

b. Remove the cable, main/flex circuit-board assembly, and BNC assembly as as one unit from the lower compensation-box half.



*When unsoldering the center conductor of the cable from the main circuit board, apply only enough heat to pull the center conductor from the connector. Using excessive or prolonged heat will irreparably damage the multi-layer main circuit board.*

c. Unsolder the cable center conductor and remove the connector from the socket on the main circuit board.

d. Resolder the new cable assembly center conductor in place, using care not to subject the circuit board to excessive or prolonged heat.

e. Reinstall the cable, main/flex circuit-board assembly, and BNC assembly into the lower compensation-box half (insert the assembly into the box half at an angle), exerting pressure toward the BNC end and against the ground spring.

f. Resolder the four power cable wires. Make sure that the proper color wire is inserted in the proper connection point (refer to Figure 7-4).

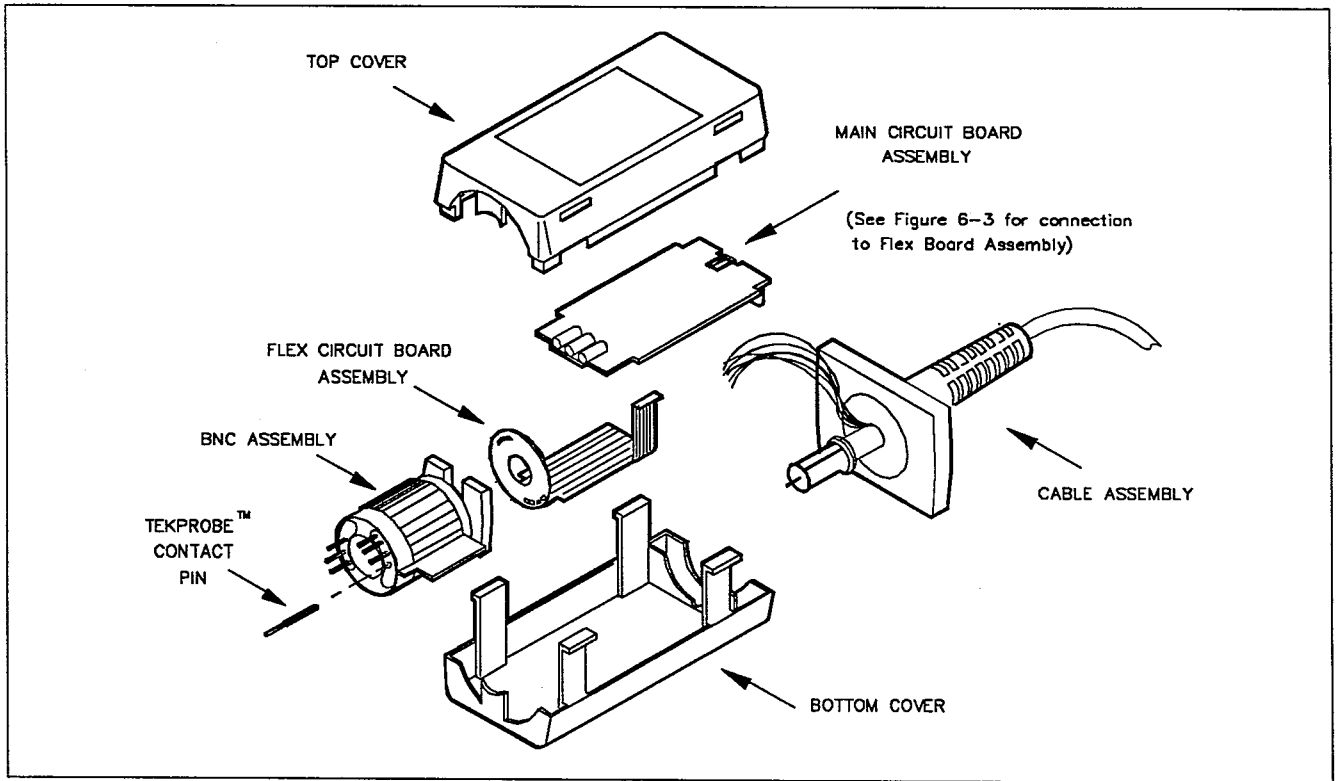

Figure 6-2. Assembly replacement.

## BNC Assembly Replacement

- a. Remove the top cover.
- b. Remove the cable, main/flex circuit-board assembly, and BNC assembly as one unit.
- c. Pull the BNC assembly from the main circuit board and unsolder the flex circuit board connections.
- d. Carefully solder the flex circuit board to the new BNC assembly and reconnect the BNC assembly to the main circuit board.
- e. Reinsert the cable, main/flex circuit-board assembly, and BNC into the lower compensation box half (refer to step e under "Cable Assembly Replacement").

## Main or Flex Circuit Board Replacement

Please refer to Figure 6-2 and Figure 6-3.

### To replace either board:

- a. Remove the compensation box cover.

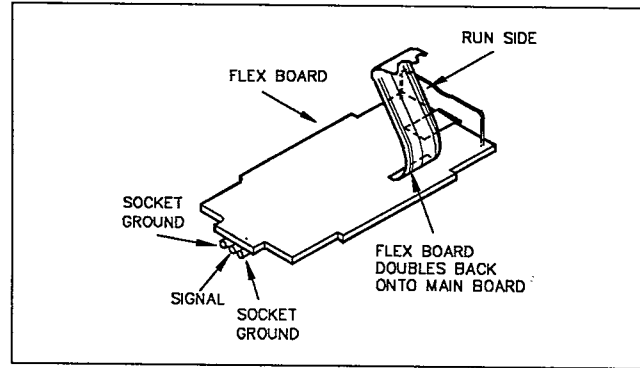

**Figure 6-3. Flex Circuit board replacement.**

- b. Remove the cable, main / flex circuit board, and BNC assembly as one unit from the lower compensation box half.

### If replacing the main circuit board:

- a. Remove the cable assembly (refer to "Cable Assembly Replacement").
- b. Pull the BNC assembly from the connector on the main circuit board.

## **CAUTION**

*The flex and main circuit boards are easily damaged by excessive heat, and the connections from the flex circuit board to the main circuit board are close together.*

*To ensure proper operation of the P6204:*

*1. Use only silver solder and a temperature-controlled soldering iron with a maximum tip temperature of 600 F.*

*2. Keep the soldering iron contact as brief as possible.*

*3. Observe and note the position of all connections. Check that there are no shorts or opens before reassembling the probe.*

c. Carefully unsolder the flex circuit-board connections from the main circuit board.

d. Carefully solder the flex circuit board to the new main circuit board.

e. Check that the connections are not shorted.

f. Reconnect the cable assembly connections.

g. Reassemble the probe.

### **If replacing the flex circuit board:**

a. Remove the BNC assembly from the main circuit board.

b. Unsolder the flex board connections to the BNC assembly.

c. Unsolder the flex board connections to the main circuit board.

d. Solder the new flex board to the main circuit board.

e. Solder the new flex board to the BNC assembly.

f. Reassemble the probe.

### **READJUSTMENT AFTER REPAIR**

After any electrical component has been replaced, complete the "Performance Check Procedure" (Section 3) to verify that the probe is within specification limits. If adjustment is necessary, perform the appropriate "Adjustment Procedure" (Section 4).

## INSTRUMENT REPACKING

### Required Reshipment Information

If the probe is to be shipped to a Tektronix Service Center for service or repair, attach a tag that contains the following information to the probe.

1. Owner's name and address, with the name of an individual at your firm that can be contacted.
2. Description of the service required.

To repack the probe, use the original carton in which your probe was shipped. If the original packing is unfit for

use or is not available, repackage the probe as follows.

1. Obtain a corrugated cardboard carton having inside dimensions of no less than 2 inches more than probe dimensions to allow cushioning. Use a carton having a test strength of at least 175 pounds.
2. Surround the probe with protective polyethylene sheeting.
3. Cushion the probe on all sides by tightly packing dunnage or urethane foam between carton and probe, allowing 2 inches on all sides.
4. Seal carton with shipping tape or industrial stapler.



# DIAGRAMS AND CIRCUIT BOARD ILLUSTRATIONS

## Symbols and Reference Designators

Electrical components shown on the diagrams are in the following units unless noted otherwise:

Capacitors = Values one or greater are in picofarads (pF).  
Values less than one are in microfarads ( $\mu$ F).

Resistors = Ohms ( $\Omega$ ).

Symbols used on the diagrams are based on USA Standard Y32.2-1967.

Logic symbology is based on MIL-STD-806B in terms of positive logic. Logic symbols depict the logic function performed and may differ from the manufacturer's data.

The following prefix letters are used as reference designators to identify components or assemblies on the diagrams.

A	Assembly, separable or repairable (circuit board, etc.)	H	Heat dissipating device (heat sink, heat radiator, etc.)	RT	Thermistor
AT	Attenuator, fixed or variable	HR	Heater HY Hybrid circuit	S	Switch
B	Motor	J	Connector, stationary portion	T	Transformer
BT	Battery	K	Relay	TC	Thermocouple
C	Capacitor, fixed or variable	L	Inductor, fixed or variable	TP	Test point
CB	Circuit breaker	LR	Inductor/resistor combination	U	Assembly, inseparable or non-repairable (integrated circuit, etc.)
CR	Diode, signal or rectifier	M	Meter	V	Electron tube
DL	Delay line	P	Connector, movable portion	VR	Voltage regulator (zener diode, etc.)
DS	Indicating device (lamp)	Q	Transistor or silicon-controlled rectifier	Y	Crystal
E	Spark Gap	R	Resistor, fixed or variable	Z	Phase shifter
F	Fuse				
FL	Filter				

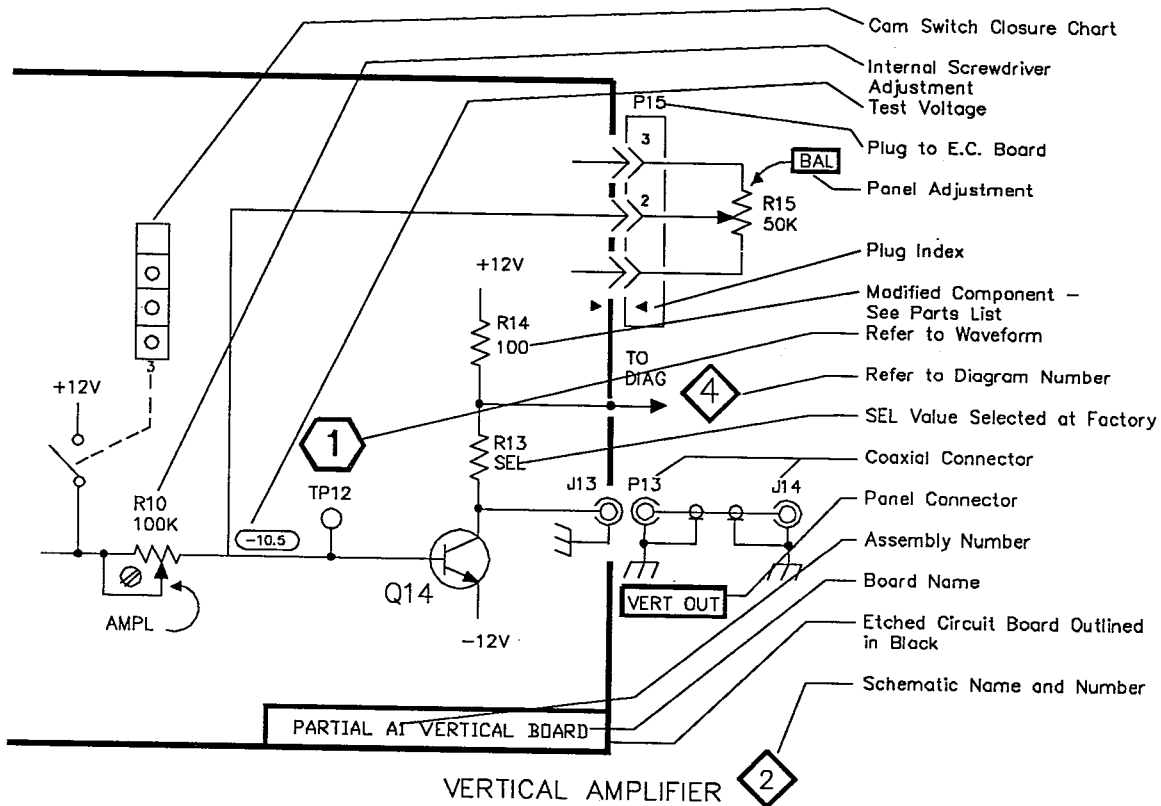

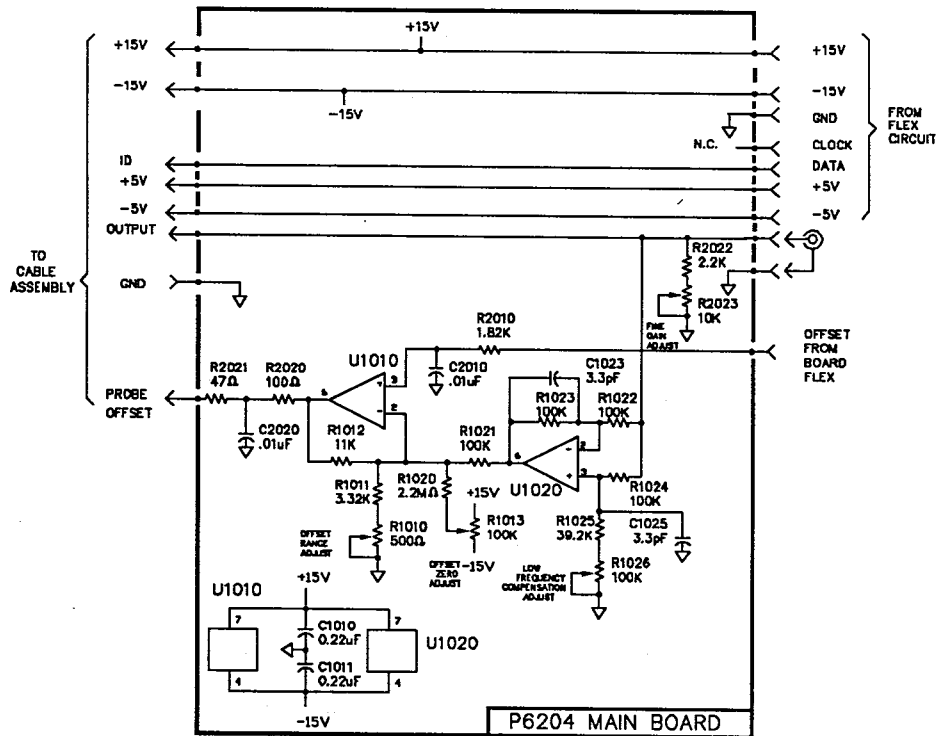

Figure 7-1. The P6204 Main board schematic

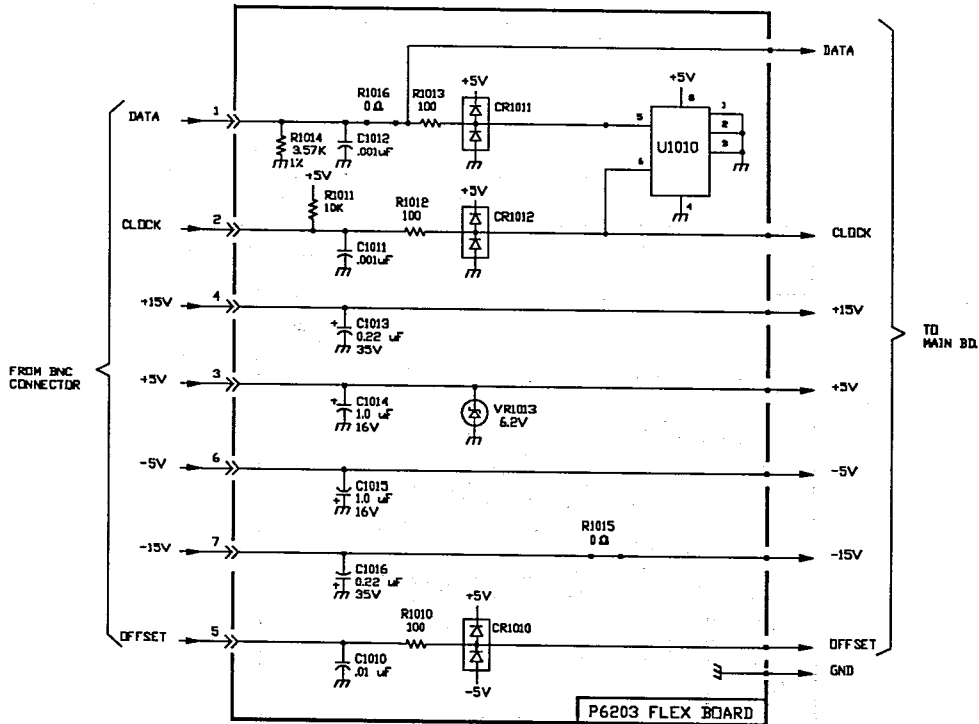
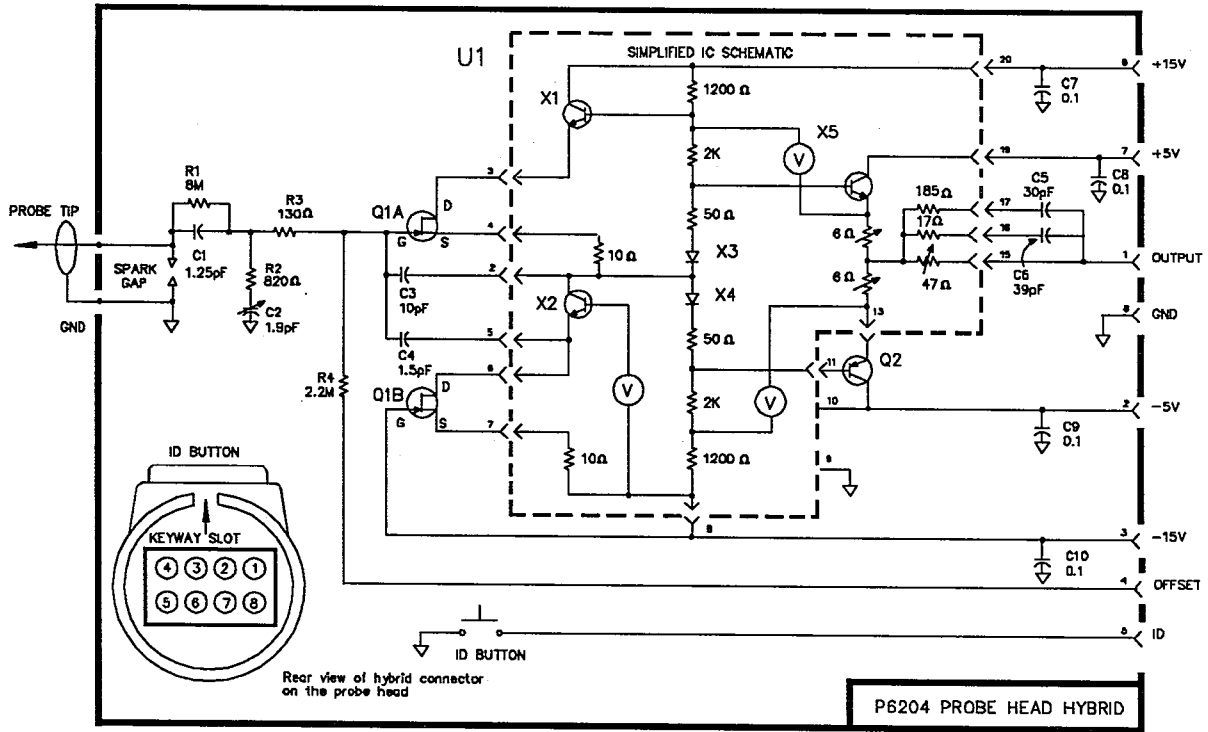

Figure 7-2. The P6204 Flex board schematic.



**Figure 7-3. The P6204 Probe Head board schematic.**

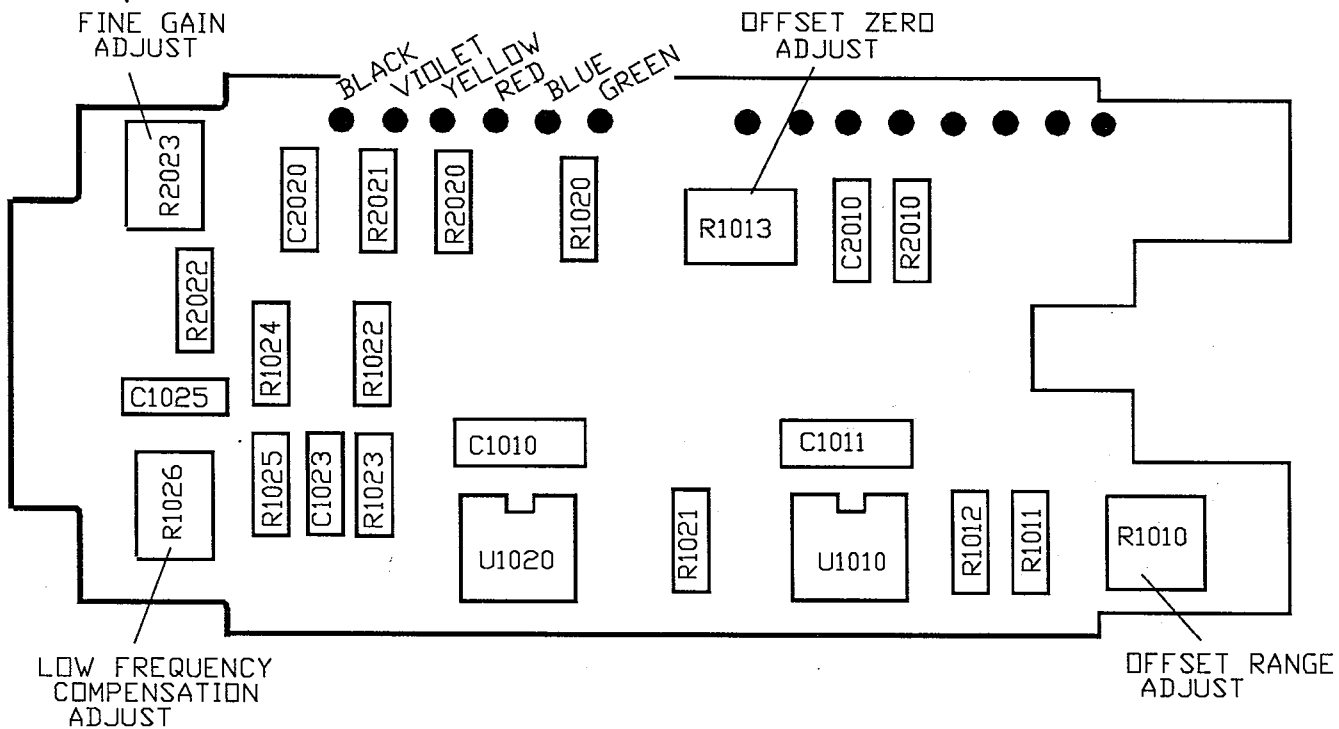

Figure 7-4. The Main Circuit board component layout.

# REPLACEABLE PARTS

## PARTS ORDERING INFORMATION

Replacement parts are available from or through your local Tektronix, Inc. Field Office or representative.

Changes to Tektronix instruments are sometimes made to accommodate improved components as they become available, and to give you the benefit of the latest circuit improvements developed in our engineering department. It is therefore important, when ordering parts, to include the following information in your order: Part number, instrument type or number, serial number, and modification number (if applicable).

If a part you have ordered has been replaced with a new or improved part, your local Tektronix, Inc. Field Office or representative will contact you concerning any change in part number.

## FIGURE AND INDEX NUMBERS

Items in this section are referenced by figure and index numbers to the illustrations.

## ITEM NAME

In the Parts List, an Item Name is separated from the description by a colon (:). Because of space limitations, an Item Name may sometimes appear as incomplete. For further Item Name identification, the U.S. Federal Cataloging Handbook H6-1 can be utilized where possible.

## INDENTATION SYSTEM

This parts list is indented to indicate item relationships. Following is an example of the indentation system used in the description column.

1	2	3	4	5	Name & Description
---	---	---	---	---	--------------------

Assembly and/or Component

*Attaching parts for Assembly and/or Component*

---\*---

Detail Part of Assembly and/or Component

*Attaching parts for Detail Part*

---\*---

Attaching Parts always appear in the same indentation as the item it mounts, while the detail parts are indented to the right. Indented parts are part of and included with, the next higher indentation. The separation symbol---\*---indicates the end of attaching parts.

**Attaching parts must be purchased separately, unless otherwise specified.**

## MFR. CODE

Indicates the code number of the actual manufacturer of the part. (Code to name and address cross reference can be found immediately after this page.)

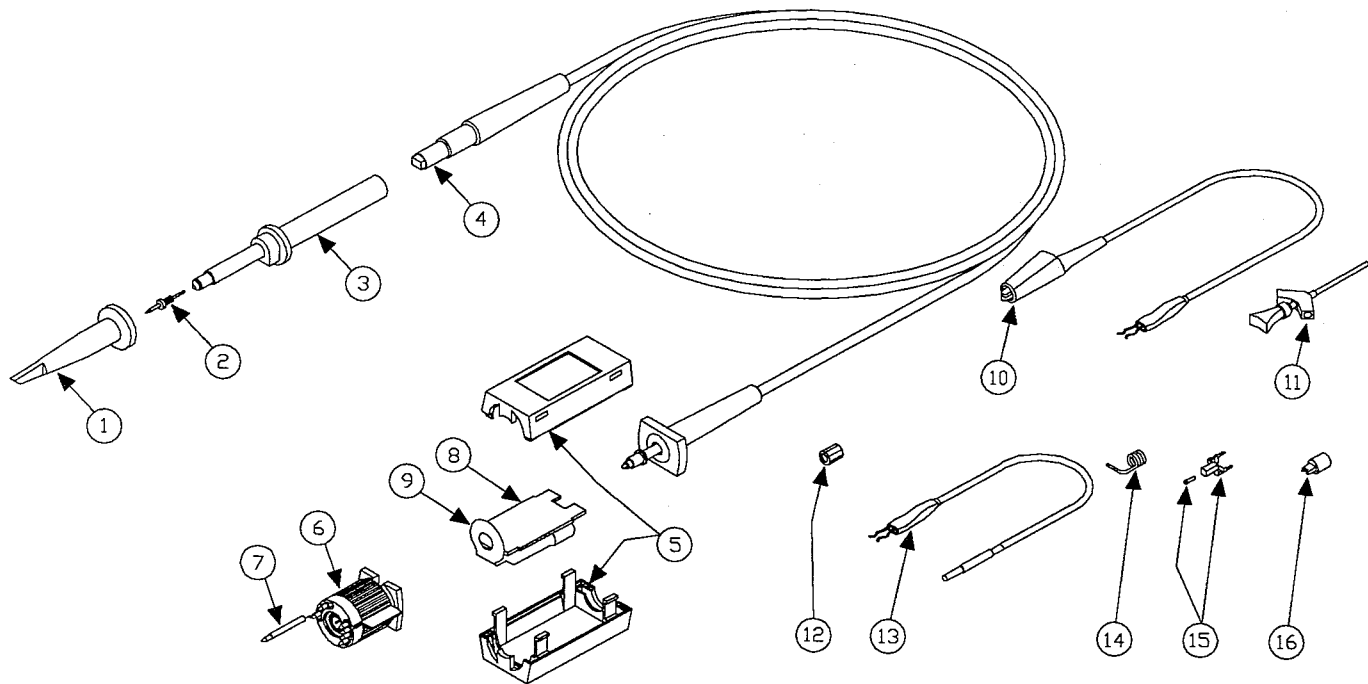



Fig. & Index No.	Tektronix Part No.	Serial/Assembly No. Effective Dscnt	Qty	12345 Name & Description	Mfr. Code	Mfr. Part No.
1-1	013-0107-06		1	TIP, PROBE: MINIATURE/COMPACT SIZE, RETRACTABLE HOOK ASSY	80009	013-0107-06
-2	131-4280-00		1	CONTACT, ELEC: PROBE TIP	80009	131-4280-00
-3	206-0390-00		1	PROBE HEAD: P6204	80009	206-0390-00
-4	174-1144-00		1	CABLE ASSY, RF: 50 OHM, 8 CONDUCTOR, 1.5 METER COVER, COMP BOX: TOP & BOTTOM, W/LABEL	80009	174-1144-00
-5	-----		1	(SEE OPTIONAL ACCESSORIES)		
-6	131-3733-00		1	CONNECTOR ASSY: BNC, 7 PIN ID	80009	131-3733-00
	131-4746-00	8850	1	CONNECTOR ASSY: BNC, 7 PIN ID W/SHELL	80009	131-4746-00
-7	131-3627-01		1	CONTACT, ELEC: GOLD PLATED TIP	18359	ORDER BY DESCR
-8	671-0634-00		1	CIRCUIT BD ASSY: MAIN COMP BOX	80009	671-0634-00
-9	670-9726-07	B010100	1	CIRCUIT BD ASSY: FLEX, TESTED	80009	670-9726-07
	670-9726-14	B012172	1	CIRCUIT BD ASSY: FLEX, TESTED	80009	670-9726-14
				STANDARD ACCESSORIES		
	020-1629-00		1	ACCESSORY KIT: P6203/P6204	80009	020-1629-00
-10	344-0398-00		1	.CLIP, ELECTRICAL: ALLIGATOR, 0.155 L, STL CS PL	80009	344-0398-00
	196-3120-00	B010800	1	.LEAD, ELECTRICAL: 23 AWG, 6.0 L, GROUND	80009	196-3120-00
-11	013-0217-00		1	.GRABBER, IC LEAD: BLACK, 2.047 L X 0.137 DIA	TK1473	973 592 500
	206-0364-00	8821	1	.TIP, PROBE: MICROCKT TEST, 0.05 CTR	80009	206-0364-00
-12	166-0404-01		1	.COVER, GROUND:	80009	166-0404-01
-13	196-3198-00		1	.LEAD, ELECTRICAL: 26 AWG, 6.0 L	80009	196-3198-00
-14	214-4125-00		1	.CONTACT, ELEC: TIP, GROUND	80009	214-4125-00
-15	-----		2	.CONN, PROBE: PROBE TO CKT BOARD ADAPTER		
				.(SEE OPTIONAL ACCESSORIES)		
-16	-----		1	.TIP, PROBE: IC TEST		
				.(SEE OPTIONAL ACCESSORIES)		
	070-6949-00		1	MANUAL, TECH: INSTRUCTION, P6204	80009	070-6949-00

REV NOV 1990

Section 8 — Replaceable Parts

Fig. & Index No.	Tektronix Part No.	Serial/Assembly No. Effective    Dscnt	Qty	12345	Name & Description	Mfr. Code	Mfr. Part No.
1-					OPTIONAL ACCESSORIES		
	003-1383-00		1		RLSE TOOL,COVER:COMP BOX,POLYCARBONATE	80009	003-1383-00
	003-1417-00	8844	1		SCREWDRIVER:ADJ TOOL,METAL TIP	52769	GTT-5G
	003-1433-00	8845	1		SCREWDRIVER:ADJUSTMENT TOOL,METAL TIP	80009	003-1433-00
	015-0201-07		1		TIP,PROBE:IC TEST,PKG OF 10	80009	015-0201-07
	015-0201-08		1		TIP,PROBE:IC TEST,PKG OF 100	80009	015-0201-08
	131-4353-00		1		CONNECTOR,PROBE:PACK OF 25	80009	131-4353-00
	-----		1		SMG50,PKG OF 20		
	003-1433-01	8845	1		SCREWDRIVER:ADJUSTMENT TOOL,PKG OF 5	80009	003-1433-01
	200-3672-00		1		COVER,COMP BOX:TOP & BOTTOM,W/LABEL RLSE TO OL & SCREWDRIVER	80009	200-3672-00

## CROSS INDEX - MFR. CODE NUMBER TO MANUFACTURER

<u>Mfr. Code</u>	<u>Manufacturer</u>	<u>Address</u>	<u>City, State, Zip Code</u>
18359	PYLON CO INC	51 NEWCOMB ST	ATTLEBORO MA 02703-1403
52769	SPRAGUE-GOODMAN ELECTRONICS INC	134 FULTON AVE	GARDEN CITY PARK NY 11040-5352
80009	TEKTRONIX INC	14150 SW KARL BRAUN DR PO BOX 500	BEAVERTON OR 97077-0001
TK1473	RICHARD HIRSCMANN OF AMERICA	PO BOX 229/INDUSTRIAL ROW	RIVERDALE NJ 07457

